

Parts List			
ITEM	PART #	DESCRIPTION	NOTES
1	K2032	Large Double Face Filler	Assembly
2	K2056	Econo Molding	Assembly
37	5217	Econo Molding Screw	Self Drilling/Tapping

Ship To:  
Order Number:

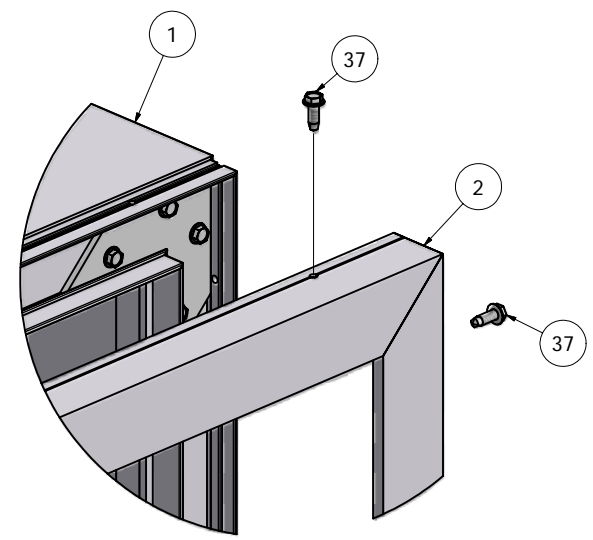
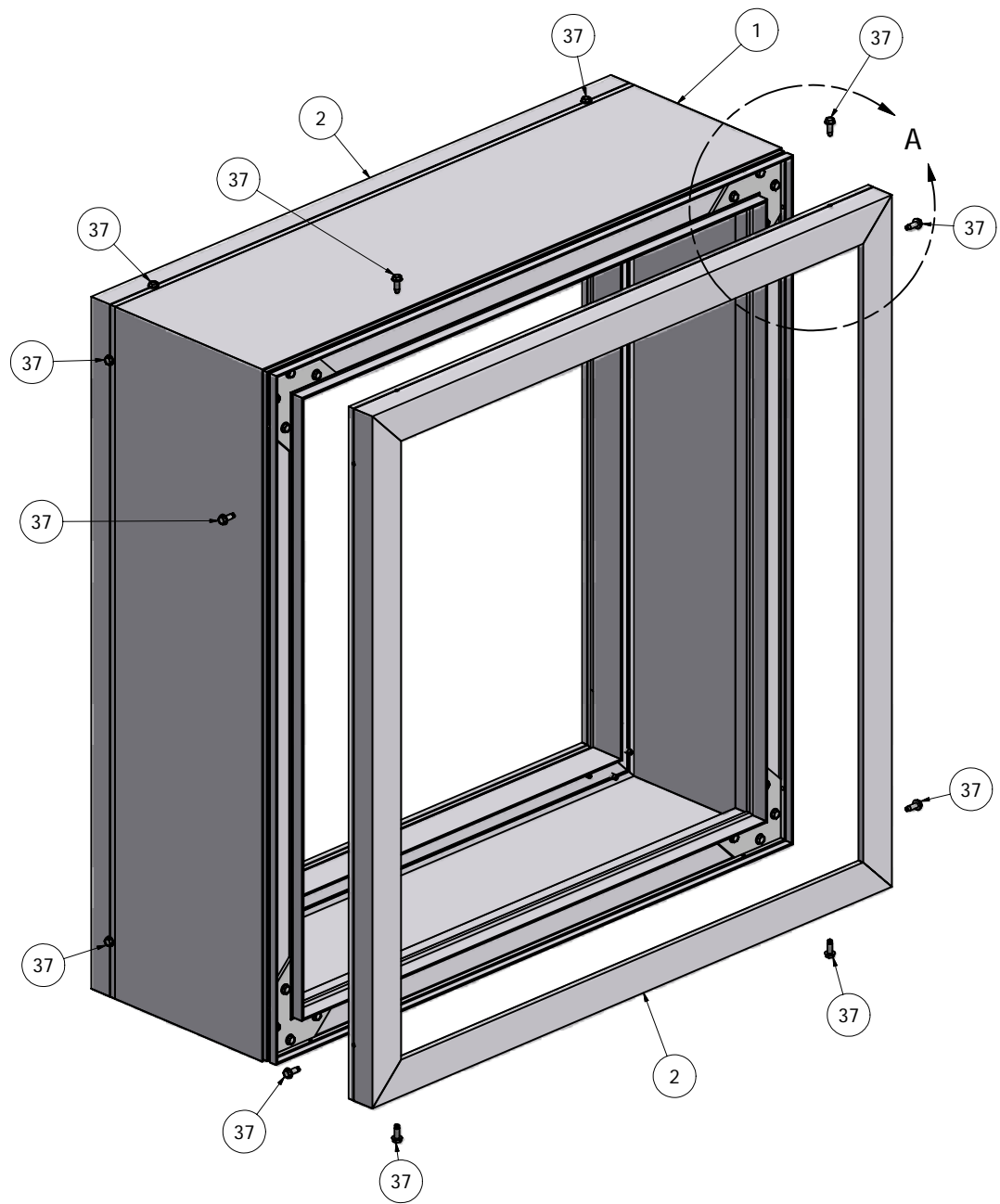

DETAIL A

**NOTE: PRE-CUT KITS ARE NOT PRE-DRILLED.**  
(Holes shown in this drawing are for reference only.  
Drilling of pilot holes are to be done by fabricator.)

THIS DRAWING WAS CREATED AT NO CHARGE TO ASSIST YOU IN VISUALIZING OUR PROPOSAL. THE DRAWING HEREIN IS THE PROPERTY OF SIGNCOMP. PERMISSION TO COPY OR REVISE THIS DRAWING OR TO USE THIS DRAWING FOR PRODUCTION IS STRICTLY PROHIBITED AND CAN ONLY BE COPIED, REVISED OR USED FOR PRODUCTION WITH THE EXPRESSED WRITTEN PERMISSION OF SIGNCOMP.

DRAWN	Steve	12/18/2008	<b>SignComp</b>		
CHECKED					
QA					
MFG					
APPROVED			TITLE Large Double Face Filler with Econo Molding - Assembly		
			SIZE C	DWG NO K2032/56	REV
			SCALE	SHEET 1 OF 1	

Parts List			
ITEM	PART #	DESCRIPTION	NOTES
1	2032	Large Double Face Filler	Top & Bottom
2	2032	Large Double Face Filler	Sides
3	5210	Corner Key	Pre-Punched
40	5217	Corner Key Screw	Self Drilling/Tapping

Ship To:

Order Number:

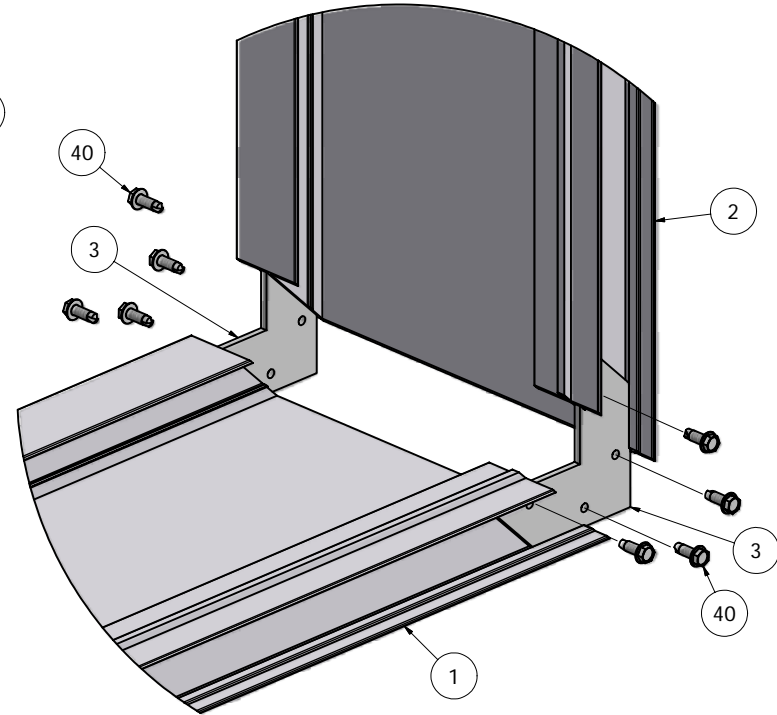
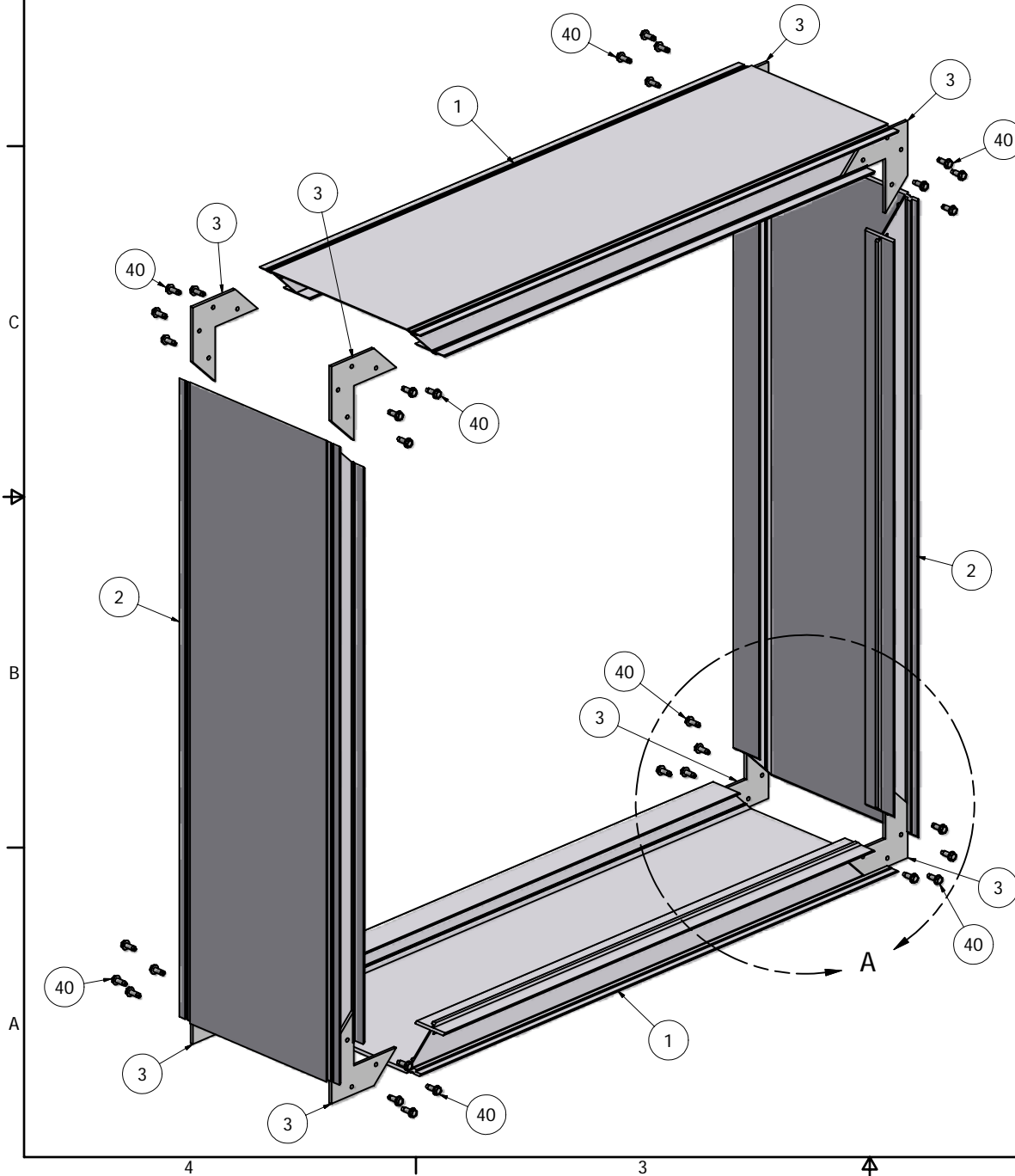

DETAIL A

**NOTE: PRE-CUT KITS ARE NOT PRE-DRILLED.**

(Holes shown in this drawing are for reference only.  
Drilling of pilot holes are to be done by fabricator.)

THIS DRAWING WAS CREATED AT NO CHARGE TO ASSIST YOU IN VISUALIZING OUR PROPOSAL. THE DRAWING HEREIN IS THE PROPERTY OF SIGNCOMP. PERMISSION TO COPY OR REVISE THIS DRAWING OR TO USE THIS DRAWING FOR PRODUCTION IS STRICTLY PROHIBITED AND CAN ONLY BE COPIED, REVISED OR USED FOR PRODUCTION WITH THE EXPRESSED WRITTEN PERMISSION OF SIGNCOMP.

DRAWN Steve	12/18/2008	<b>SignComp</b>	
CHECKED			
QA		TITLE	
MFG		Large Double Face Filler - Assembly	
APPROVED		SIZE C	DWG NO K2032
		SCALE	REV
		SHEET 1 OF 1	

Parts List			
ITEM	PART #	DESCRIPTION	NOTES
3	5210	Corner Key	Pre-punched
5	2056	Econo Molding	Top & Bottom
6	2056	Econo Molding	Sides

Ship To:  
Order Number:

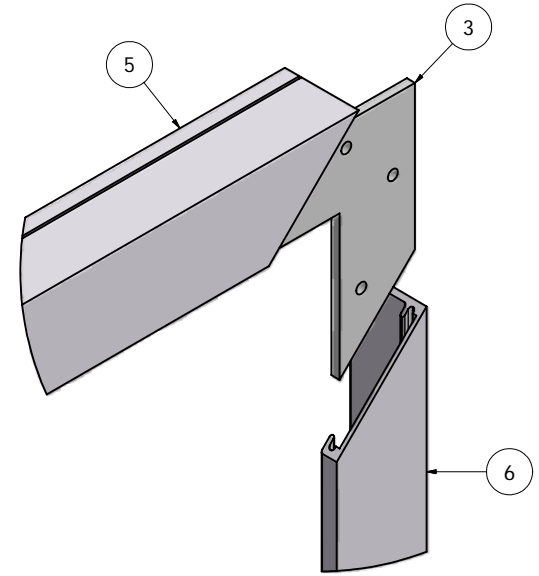
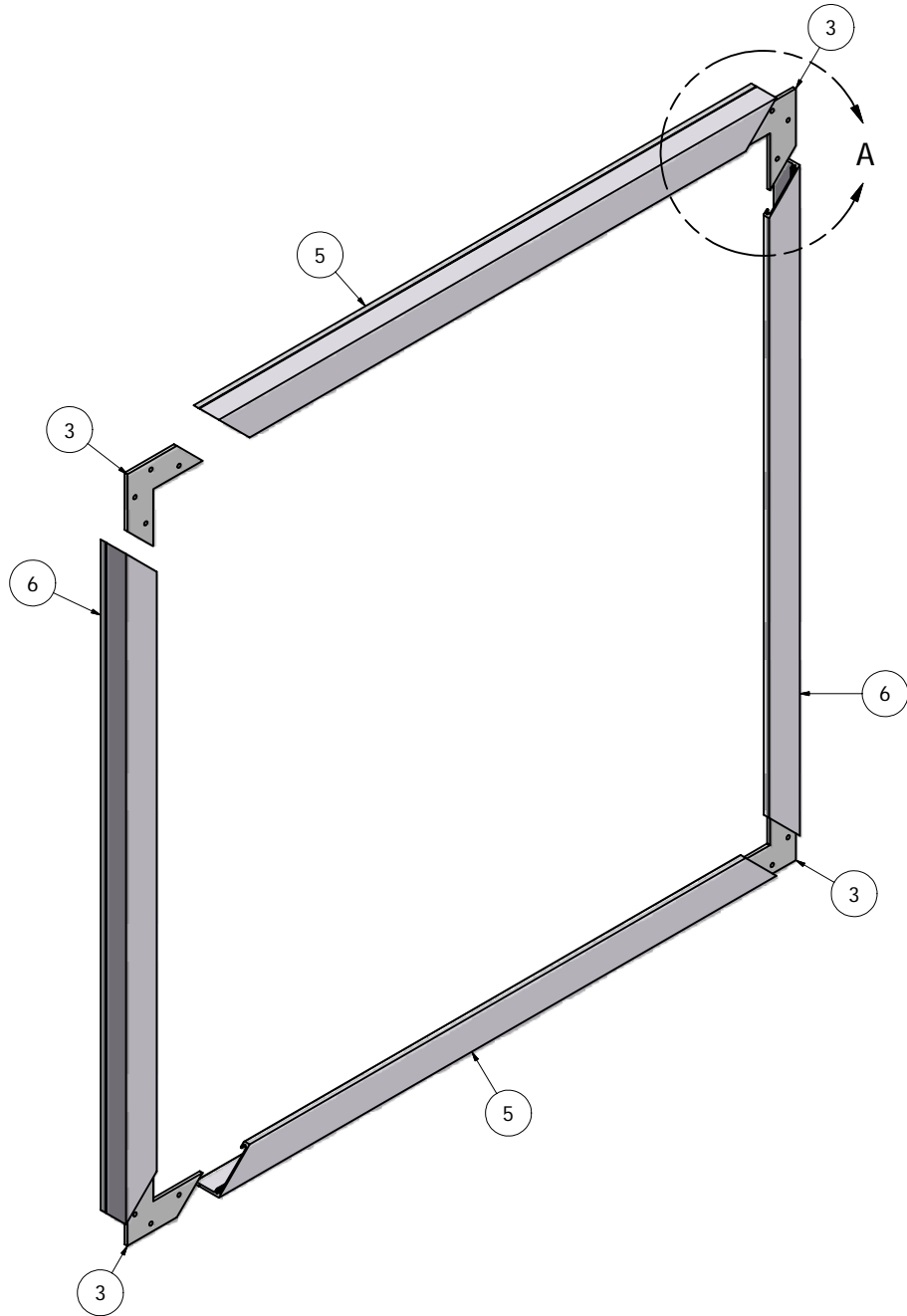

DETAIL A

**NOTE: PRE-CUT KITS ARE NOT PRE-DRILLED.**  
(Holes shown in this drawing are for reference only.  
Drilling of pilot holes are to be done by fabricator.)

THIS DRAWING WAS CREATED AT NO CHARGE TO ASSIST YOU IN VISUALIZING OUR PROPOSAL. THE DRAWING HEREIN IS THE PROPERTY OF SIGNCOMP. PERMISSION TO COPY OR REVISE THIS DRAWING OR TO USE THIS DRAWING FOR PRODUCTION IS STRICTLY PROHIBITED AND CAN ONLY BE COPIED, REVISED OR USED FOR PRODUCTION WITH THE EXPRESSED WRITTEN PERMISSION OF SIGNCOMP.

DRAWN	12/17/2008	<h1>SignComp</h1> <p>Econo Molding - Assembly</p>		
CHECKED				
QA				
MFG				
APPROVED				
		SIZE	DWG NO	REV
		C	K2056	
		SCALE	SHEET 1 OF 1	